

DIN 16742

DIN

ICS 83.140.99

Ersatz für
die 2009-10 zurückgezogene
Norm
DIN 16901:1982-11**Kunststoff-Formteile –
Toleranzen und Abnahmebedingungen;
Text Deutsch und Englisch**Plastics moulded parts –
Tolerances and acceptance conditions;
Text in German and EnglishMoulages plastiques –
Tolérances et conditions de réception;
Texte en allemand et anglais

Gesamtumfang 71 Seiten

**"Ausdrucke aus der digitalen Daten-
bank der Firma Phoenix Contact.
Vervielfältigung lt. Merkblatt 3 des DIN."**Normenausschuss Kunststoffe (FNK) im DIN
Normenausschuss Technische Grundlagen (NATG) im DIN

Contents		Page
Foreword		4
Introduction		5
1	Scope	7
2	Normative references	7
3	Terms and definitions	8
4	Symbols and abbreviated terms	9
4.1	Symbols	9
4.2	Abbreviated term	10
5	Tolerancing of plastic moulded parts	10
5.1	General	10
5.2	Indirect tolerancing by general tolerances	10
5.3	Direct tolerancing by dimension indication at nominal dimension	11
5.4	Tolerancing of draft angles	11
5.5	Dimensioning, tolerancing and measuring of radii	11
5.6	Specification of freeform surfaces	11
6	Moulding compound properties	11
6.1	General	11
6.2	Moulding shrinkage and shrinkage anisotropies	11
6.3	Moulded material stiffness or hardness	13
7	Dimensional and geometrical tolerancing	13
7.1	Dimensional tolerancing	13
7.2	Geometrical tolerancing	18
7.3	Parting line/Tool offset	20
7.4	Tolerancing of angular dimensions	21
7.5	Tolerance analysis of dimension chains	21
8	Acceptance conditions for moulded part production (ABF)	22
Annex A (informative) Dimensional reference levels for application and production of the moulded parts		23
Annex B (informative) Causes and influential factors on the moulding shrinkage of non-porous plastics		25
Annex C (informative) Orientation aids for the assignment of plastic moulding compounds to tolerance groups		26
Annex D (informative) Evaluation of the production expense		30
Annex E (informative) Validation of machine or process capability		33
Annex F (informative) Main causes for dimension, form and location deviations in moulded part production		34
Annex G (informative) Example for determining the D_p dimension for application of Table 9		35
Bibliography		36

Contents	Page
Foreword	4
Introduction	5
1 Scope	7
2 Normative references	7
3 Terms and definitions	8
4 Symbols and abbreviated terms	9
4.1 Symbols	9
4.2 Abbreviated term	10
5 Tolerancing of plastic moulded parts	10
5.1 General	10
5.2 Indirect tolerancing by general tolerances	10
5.3 Direct tolerancing by dimension indication at nominal dimension	11
5.4 Tolerancing of draft angles	11
5.5 Dimensioning, tolerancing and measuring of radii	11
5.6 Specification of freeform surfaces	11
6 Moulding compound properties	11
6.1 General	11
6.2 Moulding shrinkage and shrinkage anisotropies	11
6.3 Moulded material stiffness or hardness	13
7 Dimensional and geometrical tolerancing	13
7.1 Dimensional tolerancing	13
7.2 Geometrical tolerancing	18
7.3 Parting line/Tool offset	20
7.4 Tolerancing of angular dimensions	21
7.5 Tolerance analysis of dimension chains	21
8 Acceptance conditions for moulded part production (ABF)	22
Annex A (informative) Dimensional reference levels for application and production of the moulded parts	23
Annex B (informative) Causes and influential factors on the moulding shrinkage of non-porous plastics	25
Annex C (informative) Orientation aids for the assignment of plastic moulding compounds to tolerance groups	26
Annex D (informative) Evaluation of the production expense	30
Annex E (informative) Validation of machine or process capability	33
Annex F (informative) Main causes for dimension, form and location deviations in moulded part production	34
Annex G (informative) Example for determining the D_p dimension for application of Table 9	35
Bibliography	36

Figures

Figure 1 — Tool-specific dimensions 14
Figure 2 — Non-tool-specific dimensions 14
Figure 3 — Parting line/Tool offset.....21
Figure A.1 — Dimensional reference levels for application and production of the moulded parts23
Figure G.1 — Example diagram for determination of the D_p dimension35

Tables

Table 1 — Tolerance groups (TG) with associated basic tolerance grades (IT) according to DIN EN ISO 286-1 13
Table 2 — Plastic moulded part tolerances as symmetrical limit dimensions for sizes 15
Table 3 — Point assignment of the tolerance groups 16
Table 4 — Evaluation matrices 1 16
Table 5 — Evaluation matrices 2 16
Table 6 — Evaluation matrices 3 17
Table 7 — Evaluation matrices 4 17
Table 8 — Evaluation of the production expense 18
Table 9 — Plastic moulded part tolerances for position tolerances 19
Table 10 — General tolerances for profile forms 20
Table B.1 — Causes and influential factors on the moulding shrinkage of non-porous plastics 25
Table C.1 — Tolerance series and tolerance groups.....26
Table C.2 — Curing classification 28
Table C.3 — Assignment of thermoset moulding compounds.....29
Table D.1 — Differentiation options or required expense31

Foreword

This standard was prepared by the Working Committee NA 054-05-13 AA "Tolerances for plastics moulded parts" of the Plastics Standards Committee (FNK).

The German version of the DIN 16742 shall be taken as authoritative. No guarantee can be given with respect to the English translation.

A comma is used as the decimal marker.

Attention is drawn to the possibility that some of the elements of this document may be the subject of patent rights. DIN [and/or DKE] shall not be held responsible for identifying any or all such patent rights.

Amendments

The following changes have been made in respect to standard DIN 16901:1982-11 withdrawn in 2009-10:

- a) establishment of an extensive compatibility with international tolerance and fitting system according to ISO 1, ISO 286-1, ISO 286-2, ISO 1101, ISO 1660, ISO 5458, ISO 5459, ISO 8015, ISO 10135, ISO 14253-1, ISO 14405-1, ISO 14405-2, ISO 14406, ISO 17450-1 and ISO 17450-2;
- b) replacement of a moulding compound list to be continuously updated by a type assignment based on accuracy-relevant properties;
- c) classification of the mobilised production expense (process stability, quality assurance) for the required accuracy level from a realistic analysis of the capacity of the moulded part manufacturer in tolerances series (expense series).

Previous editions

DIN 7710: 1941-08, 1943-09, 1951-03
DIN 7710-1: 1959-05, 1965-04, 1974-01
DIN 7710-2: 1959-05, 1966-12, 1974-01
DIN 16901: 1973-07, 1982-11

Introduction

In comparison to metal materials, significantly larger deviations in respect to dimension, form and location are usually to be expected when applying and manufacturing the moulded parts. Based on particular properties of the plastics (e. g. high deformability, low stiffness), the functional accuracy requirements are much lower than for metals in order to economically manufacture moulded parts with sufficient dimensional accuracy.

The properties profile is completely different from that of the metals owing to the special structure of the plastics and their material modification options. Properties of the plastics relevant to dimensional accuracy in the moulding application and during processing by the original mould method (injection moulding, compression moulding, rotational moulding) therefore require a much different evaluation and quantification of geometrical tolerances in comparison to the metal materials. The tolerance standards applicable for metal parts therefore cannot be adopted for plastic structures, or can only be done so to a very limited extent. That makes this standard necessary for production tolerances in respect to plastic moulded parts.

The special properties profile of the plastics means that three different dimensional reference levels defined in Annex A and characterised in respect to the main influential factors have to be taken into consideration.

The following logical processing sequence shall be complied with for the cooperation relations between moulded part development, moulded part production and tool making:

a) The moulded part designer decides on the functionally required tolerances resulting from the application conditions and the assembly with consideration of the moulded part requirements.

b) The moulded part manufacturer confirms, for compliance with the relation

“functionally required tolerance \geq tolerance possible by manufacturing technology”,

the tolerances possible with the manufacturing technology for the acceptance conditions of the moulded part production, whereby economic agreements (e. g. price surcharges) may have to be incorporated. The functionally required tolerances shall always be defined in the design documentation. In this way, absurdly accurate and uneconomical “fear and habitual tolerances” are avoided.

c) The material of the moulded part is bindingly defined by the moulded part designer upon order placement. He therefore establishes the basis for determining the moulding shrinkage. After order placement, calculated values in respect to the moulding shrinkage shall be agreed between the moulded part manufacturer and toolmaker or tool designer, whereby external experience (e. g. moulded part compound manufacturer) may have to be utilised.

Depending on the moulded part compound specification, moulded part design and tool layout, the processing of the plastics has a significant effect on the dimensional stability of the moulded parts. The processing machines of the primary shaping method are complex thermodynamic-rheological compound systems, which are still processed and optimised empirically despite highly developed manufacturing technology.

Dimensionally-relevant properties of the plastics include the extreme range of the type-dependent stiffness or hardness as well as the moulding shrinkage. Unsteady and inhomogeneous tool and moulding temperatures in conjunction with orientations of microstructures and additional tolerances due to flow systems lead to property anisotropies, which cause a greater or lesser deformation (warpage, distortion, contortion) of the moulded parts. Furthermore, wall thickness differences or mass concentrations / material concentrations can be possible causes for deformation. Form, location and angle deviations are therefore connected in highly complex ways, which make standardisation much more difficult in comparison to metals.

Unavoidable process-induced deviations are therefore to be expected for the moulded part. The procedure to be followed in the case of deviations depends on the function of the moulded part and is subject to mandatory agreement:

- Eliminate deviation by design measures (strengthening ribs, material thickening, form changes etc.);
- correct deviation by specified retention in the tool;
- retain deviation and document it by limiting sample agreement or drawing correction;
- leave deviation and document by "production deviation".

NOTE Process-induced deviations can be reduced both by effective design of the moulded part and by optimisation of the production process.

1 Scope

This standard applies for the definition of possible manufacturing tolerances for plastic moulded parts. It applies exclusively for new designs from the date of issue of this standard.

It involves limit dimensions for size dimensions (two-point dimensions) as indirect tolerancing (general tolerances) and as direct tolerancing (indication of deviation at nominal size dimension).

For tolerancing of form deviation and positional deviation, profile form tolerances act as general tolerances and position tolerances for the direct tolerancing by cylindrical tolerance zone.

Procedural basis of this standard are original mould methods with closed tools such as injection moulding, injection compression moulding, transfer moulding and compression moulding of non-porous moulded parts made from thermoplastics, thermoplastic elastomers and thermosets as well as rotational moulding of thermoplastics. An analogous application of the standard is possible for special process variants, if this was agreed with the moulded part manufacturer.

Porous moulded parts (e. g. cellular plastics) as well as other moulding and processing methods do not belong to the scope of this standard. The same applies for process combinations from the original mould and forming methods (e. g. injection moulding blowing). Permissible tolerances are to be agreed for porous moulding materials.

If tolerances are required beyond the scope of the standard, these shall be agreed with the moulded part manufacturer and specified on the drawing.

Deviations from the moulded part surface quality such as sink marks, undesired flow structures and roughness as well as joint lines are not an object of this standard.

2 Normative references

The following documents that are cited in this document in whole or part are required for the application of this document. For dated references, only the edition cited applies. For undated references, the latest edition of the referenced document (including any amendments) applies.

DIN EN ISO 286-1, *Geometrical product specification (GPS) — ISO code system for tolerances on linear sizes — Part 1: Basis of tolerances, deviations and fits*

DIN EN ISO 286-2, *Geometrical product specification (GPS) — ISO code system for tolerances on linear sizes — Part 2: Tables of standard tolerance classes and limit deviations for holes and shafts*

DIN EN ISO 291:2008-08, *Plastics — Standard atmospheres for conditioning and testing (ISO 291:2008); German version EN ISO 291:2008*

DIN EN ISO 294-4, *Plastics — Injection moulding of test specimens of thermoplastic materials — Part 4: Determination of moulding shrinkage*

DIN EN ISO 527 (all parts), *Plastics — Determination of tensile properties*

DIN EN ISO 868:2003-10, *Plastics and ebonite — Determination of indentation hardness by means of a durometer (Shore hardness) (ISO 868:2003); German version EN ISO 868:2003*

DIN EN ISO 1043 (all parts), *Plastics — Symbols and abbreviated terms*

DIN EN ISO 1101, *Geometrical product specifications (GPS) — Geometrical tolerancing — Tolerances of form, orientation, location and run-out*

DIN EN ISO 5458, *Geometrical product specification (GPS) — Geometrical tolerancing — Positional tolerancing*

DIN EN ISO 5459, *Geometrical product specifications (GPS) — Geometrical tolerancing — Datums and datum systems*

DIN EN ISO 8015, *Geometrical product specification (GPS) — Fundamentals — Concepts, principles and rules*

DIN EN ISO 10135, *Geometrical product specifications (GPS) — Drawing indications for moulded parts in technical product documentation (TPD)*

DIN EN ISO 14405-1, *Geometrical product specifications (GPS) — Dimensional tolerancing — Part 1: Linear Sizes*

DIN EN ISO 14405-2, *Geometrical product specifications (GPS) — Dimensional tolerancing — Part 2: Dimensions other than linear sizes*

DIN EN ISO 18064, *Thermoplastic elastomers — Nomenclature and abbreviated terms*

DIN ISO 48, *Rubber, vulcanized or thermoplastic — Determination of hardness (hardness between 10 IRHD and 100 IRHD)*

DIN ISO 10579, *Technical drawings; dimensioning and tolerancing; non-rigid parts*

ISO 2577, *Plastics — Thermosetting moulding materials — Determination of shrinkage*

3 Terms and definitions

The terms according to DIN EN ISO 8015 and the following terms apply for the application of this document.

3.1

design documentation

documents and data necessary for complete structural description of components, assemblies or machines and devices

Note 1 to entry: These are initially 3D data records and drawings as well as part lists. They might be supplemented by measuring and test specifications. 3D data records or drawings alone only fully describe plastic moulded parts in rare exceptional cases.

Note 2 to entry: For further information see DIN EN ISO 17450-1 and DIN EN ISO 17450-2.

3.2

size

distance between opposite points whose location is precisely defined for the measurement

Note 1 to entry: For further information see DIN EN ISO 17450-1.

4 Symbols and abbreviated terms

The symbols and abbreviated terms according to DIN EN ISO 1043, DIN EN ISO 18064 and the following symbols and abbreviated terms apply for the application of this document.

4.1 Symbols

C	Tolerance mean dimension
C_A	Tolerance mean dimension for moulded part application
C_F	Tolerance mean dimension for moulded part production
C_W	Tolerance mean dimension for tool contour production
D_P	Furthest distance in the space between the element to be toleranced and the origin of the reference system used for this positional tolerancing
L_F	Moulded part dimension
L_W	Tool contour dimension
N_F	Nominal dimension for moulded part drawings
P_g	Total number of points
P_i	Point evaluation of the individual influences
T	Tolerance
t	Form and location tolerance
T_A	Moulded part application tolerance
T_F	Moulded part production tolerance
T_W	Tool contour production tolerance
VS	Moulding shrinkage
VS_{\perp}	Moulding shrinkage transverse to the melt flow direction
VS_{\parallel}	Moulding shrinkage parallel to the melt flow direction
VS_{\max}	Maximum moulding shrinkage
VS_{\min}	Minimum moulding shrinkage
VS_R	Mean calculated value for the moulding shrinkage
ΔL	Dimensional shift
ΔL_A	Application-induced dimensional shift
ΔL_V	Moulding-induced dimensional shift
ΔS	Distribution of the moulding shrinkage
ΔVS	Difference from VS_{\perp} and VS_{\parallel}

4.2 Abbreviated term

ABF	Acceptance conditions for moulded part production
ABW	Acceptance conditions for tool production
AWB	Application conditions
GA	Limit dimension
IRHD	International Rubber Hardness Degree
IT	Basic tolerance grade
NW	Non-tool-specific dimensions
TG	Tolerance group
W	Tool-specific dimensions

5 Tolerancing of plastic moulded parts

5.1 General

The independency principle according to DIN EN ISO 8015 applies when using this standard.

Deviations from this principle (e. g. envelope requirement > size ISO 14405 $\text{\textcircled{E}}$ < or similar data) shall be agreed separately between the contractual partners.

Moulded part drawings or CAD data records correspond to the nominal geometry. The tolerances are symmetrical to the nominal geometry. Asymmetrical tolerances for sizes (e. g. fit dimensions) shall be converted to a symmetrical tolerance field location by the formal nominal dimension modification to tolerance mean dimension C : $100_{-0,6} \rightarrow 99,7 \pm 0,3$.

The procedure for the verification is to be defined uniquely. In particular in the case of non-dimensionally-stable parts, the measuring concept is of special importance (functional orientation, reference system and overdetermination, gravitational influence, pretension etc.), see also DIN ISO 10579.

Unless otherwise defined, plastic moulded parts where the general tolerances are not complied with do not have to be automatically rejected if the function is not impaired.

In the case of multiple component parts, the tolerance group shall be determined for each material and indicated as a separate general tolerance (e. g. hard component according to TG 4, soft component according to TG 7).

The less accurate material forms the basis of the tolerance determination in the case of multiple material sizes.

$23\text{ }^{\circ}\text{C} \pm 2\text{ K}$ and $50\text{ \%} \pm 10\text{ \%}$ relative air humidity is defined as a standard atmosphere in the plastic range in DIN EN ISO 291. It shall be indicated in the labelling field the following note: "Tolerancing ISO 8015 $\text{\textcircled{AD}}$ – DIN EN ISO 291:2008-08".

5.2 Indirect tolerancing by general tolerances

Only series 1 (standard production) according to Table 8 applies for general tolerances. General tolerances shall be indicated in or on the labelling field, for example: General tolerances DIN 16742 – TG6.

The profile form tolerances apply as general tolerances, a reference system shall be determined for this.

Should general toleranced dimensions be submitted to an orientating dimension control, they have to be indicated with respect to the metrological feasibility in the drawing.

5.3 Direct tolerancing by dimension indication at nominal dimension

Acceptance dimensions are all directly toleranced characteristics. All dimensions with general tolerances are not considered in the test record.

Position tolerances are not general tolerances. If required by the function, they shall be entered directly in the drawing.

The dimensional tolerance shall be indicated directly by dimensions for moulded parts dimensions with justifiably high dimensional stability requirements. When doing so, it shall be noted that the dimensional boundary lines or points represent inspection dimensions (reference dimensions, acceptance dimensions). The number of directly toleranced dimensions per moulded part shall be kept as low as possible for economic reasons.

5.4 Tolerancing of draft angles

Drafts (also draft angles) are production-induced inclinations on the moulded part in the demoulding orientation of moving tool parts (e. g. punches, gate valves, jaws), which are specified as an integral component of the moulded part drawings or the CAD data records of the moulded part manufacturer for tool design and tool making as well as parts production. Inclination dimension differences specified in terms of design are not a component of dimensional tolerances or form and location deviations.

Measuring points shall be defined at suitable areas for functional dimensions in the specification in order to define two-point dimensions.

5.5 Dimensioning, tolerancing and measuring of radii

Minimum 90° of the circle segment shall be provided as a measurable contour for the specification of radii.

NOTE Radii can alternatively be toleranced by profile forms.

5.6 Specification of freeform surfaces

Free form surfaces shall be specified with a profile form tolerance. The verification shall be coordinated.

6 Moulding compound properties

6.1 General

This standard does not contain any type lists for moulding compounds or their assignment to attainable production accuracies. Accuracy-relevant properties shall be considered in order to indicate a general assignment scheme for the large number and variety of moulding compounds.

6.2 Moulding shrinkage and shrinkage anisotropies

The moulding shrinkage (VS) is the relative difference between the tool contour dimension L_W at 23 °C ± 2 K and the corresponding moulded part dimensions L_F 16 h to 24 h after production, stored until measurement and measured at 23 °C ± 2 K and 50 % ± 10 % air humidity. It is calculated according to equation (1).

$$VS = \left(1 - \frac{L_F}{L_W} \right) \times 100 [\%] \quad (1)$$

Where

L_F is the moulded part dimension;

L_W is the tool contour dimension.

The moulding shrinkage for thermoplastics and thermoplastic elastomers is determined (e. g. test panels) according to DIN EN ISO 294-4 and for thermosets according to ISO 2577 on standard test specimens. Physical causes of the moulding shrinkage and the effect of influencing factors are indicated in Annex B and Annex F.

Shrinkage anisotropy is quantified by the absolute difference ΔVS from moulding shrinkage transverse to the melt flow direction VS_{\perp} and the moulding shrinkage parallel to the melt flow direction VS_{\parallel} . See equation (2).

$$\Delta VS = | VS_{\perp} - VS_{\parallel} | \quad (2)$$

Physical main causes are the:

- moulding impediments as a result of different thermal contraction by solidified boundary layers, material concentrations and locally different tool contour temperatures as well as by the effect of the moulded part design;
- moulding differences due to anisotropic strengthening materials (e. g. fabrics, knitted fabrics, rovings);
- orientation of filling and strengthening materials, molecules and morphological structures due to flowing processes as a result of shear and elongation flows. In particular, particle shape and aspect ratio (length-thickness ratio or side-thickness ratio) of the filling and strengthening materials affect the anisotropy characteristics.

It can be derived from the diverse influences on the moulding shrinkage and shrinkage anisotropy that numerical values are only realistic as range data. The resultant distribution of the moulding shrinkage ΔS is derived from the extreme values VS_{\max} and VS_{\min} . It is calculated according to equation (3).

$$\Delta S = VS_{\max} - VS_{\min} \quad (3)$$

The size range of the shrinkage distribution can be affected by production conditions (process optimisation), batch-relevant moulding compound differences, moulded part shape and spur technology.

Average calculated values of the moulding shrinkage VS_R are specifications for tool design, construction and sampling of the tools. It is calculated according to equation (4).

$$VS_R = 0,5 (VS_{\max} + VS_{\min}) \quad (4)$$

This calculated value, which is a basis for the tool design, is primarily expected from the moulded part manufacturer, as the latter can actively influence the shrinkage in limits and usually has corresponding data. They can be generated as a by-product from dimensional check measurements. In special cases, the shrinkage values are to be made more precise by sampling with similar tools. In addition, the moulded part manufacturer can use corresponding data and experience of the moulding compound manufacturer. In the case of distinct shrinkage anisotropy, the shrinkage differences can be considered to a limited extent by dimensional provisions in the tool. Computer-assisted shrinkage and deformation statements might be able to provide information in respect to this.

The shrinkage distribution is also of major significance for the attainable production accuracy. This value range is to be estimated according to experience of the moulded part manufacturer.

NOTE If the shrinkage anisotropy cannot be considered adequately in the contour calculation, a larger shrinkage distribution and hence deformation is to be expected. A timely coordination between the customer and moulded part manufacturer is necessary in respect to this.

6.3 Moulded material stiffness or hardness

The elastic recovery (relaxation) of the moulding material after removal of the part has a significant effect on the length dimensions. The main cause for this is the different stiffness or hardness of the moulding material directly after removal from the mould. It is quantified by the original modulus of elasticity from the short-term test according to DIN EN ISO 527 as well as by the Shore indentation hardness according to DIN EN ISO 868:2003-10 (method A and method D) or by the ball indentation hardness for elastomers according to DIN ISO 48 (International Rubber Hardness Degree). All tests refer to 23 °C and normally conditioned test specimens. The required data can be found in the specifications of the moulding compound suppliers.

7 Dimensional and geometrical tolerancing

7.1 Dimensional tolerancing

7.1.1 Tolerance groups for size elements

In order to approximately adapt the distribution of the production tolerances resulting from the moulding compound and process and their particular nominal dimensional relation for plastic moulded parts to the ISO system for limit dimensions and fits according to DIN EN ISO 286-1 and -2, nine tolerance groups (TG1 to TG9) in four nominal dimension ranges were assigned to the ISO basic tolerance grades (IT) for tool-specific dimensions in Table 1.

Table 1 — Tolerance groups (TG) with associated basic tolerance grades (IT) according to DIN EN ISO 286-1

Nominal dimension mm	ISO standard tolerance grades (IT) for tool-specific dimensions								
	TG1	TG2	TG3	TG4	TG5	TG6	TG7	TG8	TG9
1 to 6	8	9	10	11	12	13	14	15	16
> 6 to 120	9	10	11	12	13	14	15	16	17
> 120 to 500	–	11	12	13	14	15	16	17	18
> 500 to 1000	–	–	13	14	15	16	17	18	N.N

The tolerances are subject to mandatory agreement as a rule for nominal dimensions below 1 mm and above 1000 mm.

NOTE Table 1 is to be understood as information for the basic layout and content of Table 2. No use is necessary either.

The permissible limit dimensions for plastic moulded parts are summarised for the practical application in Table 2.

The production method rotational moulding is classified into tolerance group 9.

Different deformations and deviations of location of tool parts for the pressure load are recorded by the differentiation of tool-specific and non-tool-specific moulded part dimensions, as the type of tool contour locking embodies different degrees of accuracy. Tool-specific dimensions are dimensions in the same tool part, while non-tool-specific dimensions are derived from the interaction of different tool parts and which hence tend to cause larger dimensional distributions (Figure 1 and Figure 2).

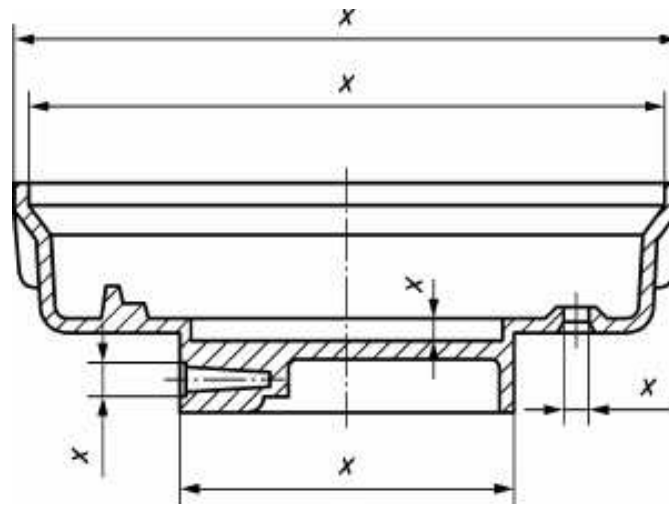
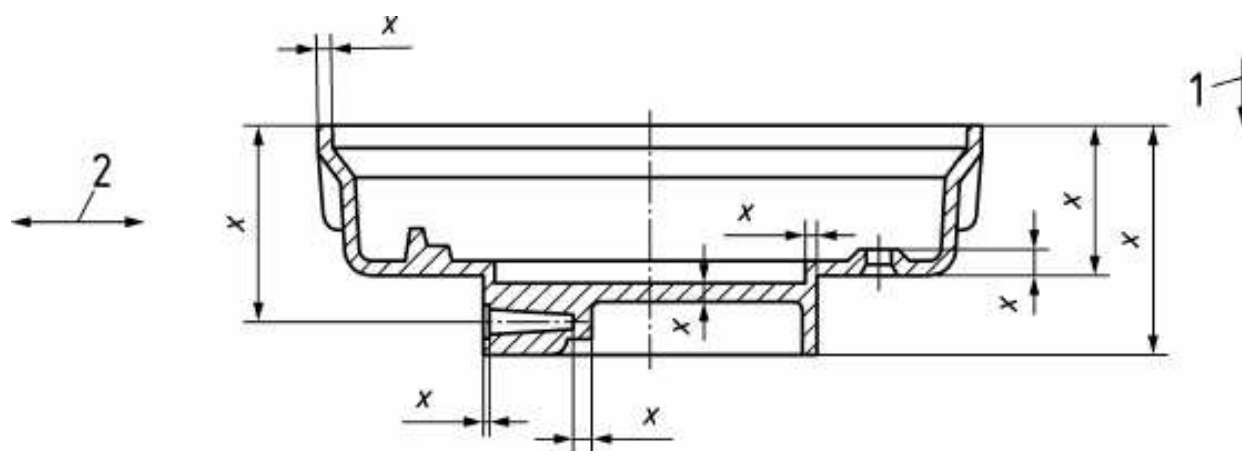

Figure 1 — Tool-specific dimensions



Key

- 1 Closing direction
- 2 Movement direction of the gate valve

Figure 2 — Non-tool-specific dimensions

Table 2 — Plastic moulded part tolerances as symmetrical limit dimensions for sizes

Dimensions in millimetres

Tolerance group		Limit dimensions (GA) for nominal size ranges															
		1 to 3	> 3 to 6	> 6 to 10	> 10 to 18	> 18 to 30	> 30 to 50	> 50 to 80	> 80 to 120	> 120 to 180	> 180 to 250	> 250 to 315	> 315 to 400	> 400 to 500	> 500 to 630	> 630 to 800	> 800 to 1000
TG1	W	± 0,007	± 0,012	± 0,018	± 0,022	± 0,026	± 0,031	± 0,037	± 0,044	—	—	—	—	—	—	—	—
	NW	± 0,012	± 0,018	± 0,022	± 0,026	± 0,031	± 0,037	± 0,044	± 0,050	—	—	—	—	—	—	—	—
TG2	W	± 0,013	± 0,020	± 0,029	± 0,035	± 0,042	± 0,050	± 0,060	± 0,090	± 0,13	± 0,15	± 0,16	± 0,18	± 0,20	—	—	—
	NW	± 0,020	± 0,029	± 0,035	± 0,042	± 0,050	± 0,060	± 0,090	± 0,13	± 0,15	± 0,16	± 0,18	± 0,20	± 0,22	—	—	—
TG3	W	± 0,020	± 0,031	± 0,05	± 0,06	± 0,07	± 0,08	± 0,10	± 0,15	± 0,20	± 0,23	± 0,26	± 0,29	± 0,40	± 0,55	± 0,63	± 0,70
	NW	± 0,031	± 0,050	± 0,06	± 0,07	± 0,08	± 0,10	± 0,15	± 0,20	± 0,23	± 0,26	± 0,29	± 0,40	± 0,55	± 0,63	± 0,70	± 0,77
TG4	W	± 0,03	± 0,05	± 0,08	± 0,09	± 0,11	± 0,13	± 0,15	± 0,23	± 0,32	± 0,35	± 0,41	± 0,45	± 0,63	± 0,88	± 1,00	± 1,15
	NW	± 0,05	± 0,08	± 0,09	± 0,11	± 0,13	± 0,15	± 0,23	± 0,32	± 0,35	± 0,41	± 0,45	± 0,63	± 0,88	± 1,00	± 1,15	± 1,30
TG5	W	± 0,05	± 0,08	± 0,11	± 0,14	± 0,17	± 0,20	± 0,23	± 0,36	± 0,50	± 0,58	± 0,65	± 0,70	± 1,00	± 1,40	± 1,60	± 1,80
	NW	± 0,08	± 0,11	± 0,14	± 0,17	± 0,20	± 0,23	± 0,36	± 0,50	± 0,58	± 0,65	± 0,70	± 1,00	± 1,40	± 1,60	± 1,80	± 2,10
TG6	W	± 0,07	± 0,12	± 0,18	± 0,22	± 0,26	± 0,31	± 0,37	± 0,57	± 0,80	± 0,93	± 1,05	± 1,15	± 1,60	± 2,20	± 2,50	± 2,80
	NW	± 0,12	± 0,18	± 0,22	± 0,26	± 0,31	± 0,37	± 0,57	± 0,80	± 0,93	± 1,05	± 1,15	± 1,60	± 2,20	± 2,50	± 2,80	± 3,10
TG7	W	± 0,13	± 0,20	± 0,29	± 0,35	± 0,42	± 0,50	± 0,60	± 0,90	± 1,25	± 1,45	± 1,60	± 1,80	± 2,60	± 3,50	± 4,00	± 4,50
	NW	± 0,20	± 0,29	± 0,35	± 0,42	± 0,50	± 0,60	± 0,90	± 1,25	± 1,45	± 1,60	± 1,80	± 2,60	± 3,50	± 4,00	± 4,50	± 5,00
TG8	W	± 0,20	± 0,31	± 0,45	± 0,55	± 0,65	± 0,80	± 0,95	± 1,40	± 2,00	± 2,30	± 2,60	± 2,85	± 4,00	± 5,50	± 6,25	± 7,00
	NW	± 0,31	± 0,45	± 0,55	± 0,65	± 0,80	± 0,95	± 1,40	± 2,00	± 2,30	± 2,60	± 2,85	± 4,00	± 5,50	± 6,25	± 7,00	± 7,75
TG9		± 0,30	± 0,49	± 0,75	± 0,90	± 1,05	± 1,25	± 1,50	± 2,25	± 3,15	± 3,60	± 4,05	± 4,45	± 6,20	± 8,50	± 10,00	± 11,50

NOTE 1 W: Tool-specific dimensions; NW: Non-tool-specific dimensions.
 NOTE 2 The differentiation of tool-specific and non-tool-specific dimension is not necessary for TG9.
 NOTE 3 Tolerance mean dimensions apply as nominal sizes for moulded part drawings ($V_F = C_F$). For tolerancing of the distance between parallel surfaces that do not face each other directly but are arranged shifted to one another, the D_p dimension according to 7.2 of this standard is to be used as nominal size.
 NOTE 4 Dimensions under 1 mm and above 1 000 mm are subject to mandatory agreement.
 NOTE 5 Only the limit values for non-tool-specific dimensions are to be used for general tolerances.
 NOTE 6 Tolerances for material thicknesses are subject to mandatory agreement.
 NOTE 7 General tolerances are to be indicated in the design documentation as follows. Example: DIN 16742 – TG6.
 NOTE 8 For validation of machine and process capability, see Annex E.

7.1.2 Determination of the tolerance groups

7.1.2.1 General

The required degree of accuracy of the moulded part production is defined with the corresponding tolerance group according to Table 1. An oriented assignment scheme using point evaluation of five individual influences P_i with the total number of points P_g yields the tolerance group according to Table 3:

$$P_g = P_1 + P_2 + P_3 + P_4 + P_5 \tag{5}$$

where

P_g the total number of points;

P_i the point evaluation of the individual influences.

Table 3 — Point assignment of the tolerance groups

TG	TG1	TG2	TG3	TG4	TG5	TG6	TG7	TG8	TG9
P_g	1	2	3	4	5	6	7	8	≥ 9

In the limit areas of the decision making, the tolerance group assignment is also the responsibility of the user without continuous point evaluation. A coordination with the moulded part manufacturer might then be necessary.

7.1.2.2 Evaluation of the production process and moulding compound properties (P_1 to P_4)

7.1.2 Determination of the tolerance groups

7.1.2.1 General

The required degree of accuracy of the moulded part production is defined with the corresponding tolerance group according to Table 1. An oriented assignment scheme using point evaluation of five individual influences P_i with the total number of points P_g yields the tolerance group according to Table 3:

$$P_g = P_1 + P_2 + P_3 + P_4 + P_5 \quad (5)$$

where

P_g the total number of points;

P_i the point evaluation of the individual influences.

Table 3 — Point assignment of the tolerance groups

TG	TG1	TG2	TG3	TG4	TG5	TG6	TG7	TG8	TG9
P_g	1	2	3	4	5	6	7	8	≥ 9

In the limit areas of the decision making, the tolerance group assignment is also the responsibility of the user without continuous point evaluation. A coordination with the moulded part manufacturer might then be necessary.

7.1.2.2 Evaluation of the production process and moulding compound properties (P_1 to P_4)

The point assignment is conducted with the following evaluation matrices (see Table 4, 5, 6 and 7), whereby the evaluation is at the user's discretion for limit ranges of the properties (P_2 to P_4).

Table 4 — Evaluation matrices 1

Production process	P_1
Injection moulding, injection compression moulding, transfer moulding	1
Compression moulding, impact extrusion	2

Table 5 — Evaluation matrices 2

Moulded material stiffness or hardness			P_2
Modulus of elasticity N/mm ²	Shore D	Shore A; IRHD	
above 1 200	above 75	–	1
above 30 to 1 200	above 35 to 75	–	2
3 to 30	–	50 to 90	3
below 3	–	below 50	4

Table 6 — Evaluation matrices 3

Moulding shrinkage (calculated value)	P_3
below 0,5 %	0
0,5 % to 1 %	1
above 1 % to 2 %	2
above 2 %	3
The maximum shrinkage characteristic value is definitive for the assignment in the case of shrinkage anisotropy.	

Table 7 — Evaluation matrices 4

Consideration of the shrinkage differences due to geometry and process	P_4
Precisely possible: Calculated values of the VS are known. (For example from experience, systematic measurements, computer simulations.) Shrinkage anisotropy is meaningless or can be considered sufficiently accurately in the relevant dimensional orientation. Possible deviations from the calculated value are max. $\pm 10\%$.	1
Precisely possible with limitations: Calculated values of the VS are known in ranges max. to $\pm 20\%$.	2
Only imprecisely possible: Calculated values of the VS are only known as rough guide values ranges. Shrinkage anisotropy cannot be considered or can only be considered inadequately. Practical experience for estimating relevant calculated values is not available. Possible deviations from the calculated value are above $\pm 20\%$.	3
In general, it is assumed that the shrinkage fluctuations due to variations in the processing conditions and differences in the moulding compound properties can be approximately $\pm 30\%$ of the calculated value of the VS. The selection $P_4 = 3$ is to be made if no other information is available.	

NOTE 1 After determining P_1 to P_4 and their addition, it should be checked whether the structurally required tolerance can be attained technologically with series 1 (normal production). If this is fulfilled, all further considerations will be sufficient. The increase in the production expense contained in P_5 only has to be considered if the functionally required tolerance is not attained.

NOTE 2 The method according to Annex C can be used as an oriented assignment for moulding compounds. This method does not replace the detailed point evaluation.

7.1.2.3 Evaluation of the production expense (P_5)

The expense necessary for the moulded part manufacturer for production and quality assurance is definitive for the level of the production accuracy. A differentiation is made by tolerance series (see Table 8).

Table 8 — Evaluation of the production expense

Tolerance series		P_5
Series 1 (normal production)	Production realised with general tolerances. Dimensional stability requirements that do not form any special quality focus.	0
Series 2 (accurate production)	Production and quality assurance are oriented to higher dimensional stability requirements.	-1
Series 3 (precision production)	Full alignment of production and quality assurance to the very high dimensional stability requirements.	-2
Series 4 (precision special production)	As series 3, but with more intensive process monitoring.	-3
The tolerance series 3 (precision production) and 4 (precision special production) are always subject to mandatory agreement.		

Exemplary selection criteria are listed in Annex D to assist the series assignment.

NOTE If a higher accuracy level (series 2, series 3 and series 4) is necessary for directly toleranced dimensions, the series assignment should be performed after evaluation of the necessary fulfilment degree of the questions below:

- Are the moulded parts devised to be plastic compatible and optimally designed and dimensioned in respect to dimensional stability?
- Are the tools functionally reliable as well as sufficiently stiff mechanically, thermally and rheologically balanced?
- Do machines, systems and devices as well as the operating personnel ensure a sufficiently precise production workflow including quality assurance?
- Are corresponding terms of delivery agreed in respect to the dimensionally-relevant properties level of the moulding compounds, in particular the shrinkage fluctuations, and are these checked?

The expense currently to be realised by the moulded part manufacturer is derived from the required dimensional tolerances. Precision productions (series 3 and series 4) are special cases whose realisation might require special agreements between the buyer and manufacturer of the moulded parts from an economic operational viewpoint (e. g. price surcharges) as well. It should therefore be expressly noted that unnecessarily high tolerance requirements lead to unnecessarily high moulded part costs.

7.2 Geometrical tolerancing

Any form and location tolerancing¹⁾ shall be agreed between the buyer and manufacturer of the moulded parts. DIN EN ISO 1101 and DIN EN ISO 5458 in a reference system according to DIN EN ISO 5459 apply for area form, line form and position tolerances.

A component can have one or more reference systems. The furthest distance of the toleranced element to the origin of the reference system used for the position tolerance (D_P) shall be applied to determine the position tolerance. This does not have to correspond to the coordinate system of the component or from the assembly. The D_P dimension is the nominal dimension for determination of the position tolerance according to Table 9. The same also applies to profile form tolerances according to Table 10.

¹⁾ This also includes, in particular, the freeform surfaces.

Table 9 — Plastic moulded part tolerances for position tolerances

Tolerance group		Diameter of the cylindrical tolerance zones for the D_P nominal dimension ranges															
		1 to 3	> 3 to 6	> 6 to 10	> 10 to 18	> 18 to 30	> 30 to 50	> 50 to 80	> 80 to 120	> 120 to 180	> 180 to 250	> 250 to 315	> 315 to 400	> 400 to 500	> 500 to 630	> 630 to 800	> 800 to 1000
TG1	W	Ø 0,020	Ø 0,034	Ø 0,05	Ø 0,06	Ø 0,07	Ø 0,09	Ø 0,11	Ø 0,12	-	-	-	-	-	-	-	-
	NW	Ø 0,034	Ø 0,05	Ø 0,06	Ø 0,07	Ø 0,09	Ø 0,11	Ø 0,12	Ø 0,14	-	-	-	-	-	-	-	-
TG2	W	Ø 0,04	Ø 0,06	Ø 0,08	Ø 0,10	Ø 0,12	Ø 0,14	Ø 0,17	Ø 0,26	Ø 0,37	Ø 0,42	Ø 0,45	Ø 0,51	Ø 0,57	-	-	-
	NW	Ø 0,06	Ø 0,08	Ø 0,10	Ø 0,12	Ø 0,14	Ø 0,17	Ø 0,26	Ø 0,37	Ø 0,42	Ø 0,45	Ø 0,51	Ø 0,57	Ø 0,62	-	-	-
TG3	W	Ø 0,06	Ø 0,09	Ø 0,14	Ø 0,17	Ø 0,20	Ø 0,23	Ø 0,28	Ø 0,42	Ø 0,57	Ø 0,65	Ø 0,74	Ø 0,82	Ø 1,1	Ø 1,6	Ø 1,8	Ø 2,0
	NW	Ø 0,09	Ø 0,14	Ø 0,17	Ø 0,20	Ø 0,23	Ø 0,28	Ø 0,42	Ø 0,57	Ø 0,65	Ø 0,74	Ø 0,82	Ø 1,1	Ø 1,6	Ø 1,8	Ø 2,0	Ø 2,2
TG4	W	Ø 0,08	Ø 0,14	Ø 0,23	Ø 0,25	Ø 0,31	Ø 0,37	Ø 0,42	Ø 0,65	Ø 0,90	Ø 1,0	Ø 1,2	Ø 1,3	Ø 1,8	Ø 2,5	Ø 2,8	Ø 3,3
	NW	Ø 0,14	Ø 0,23	Ø 0,25	Ø 0,31	Ø 0,37	Ø 0,42	Ø 0,65	Ø 0,90	Ø 1,0	Ø 1,2	Ø 1,3	Ø 1,8	Ø 2,5	Ø 2,8	Ø 3,3	Ø 3,7
TG5	W	Ø 0,14	Ø 0,23	Ø 0,31	Ø 0,40	Ø 0,48	Ø 0,57	Ø 0,65	Ø 1,0	Ø 1,4	Ø 1,6	Ø 1,8	Ø 2,0	Ø 2,8	Ø 4,0	Ø 4,5	Ø 5,1
	NW	Ø 0,23	Ø 0,31	Ø 0,40	Ø 0,48	Ø 0,57	Ø 0,65	Ø 1,0	Ø 1,4	Ø 1,6	Ø 1,8	Ø 2,0	Ø 2,8	Ø 4,0	Ø 4,5	Ø 5,1	Ø 5,9
TG6	W	Ø 0,20	Ø 0,34	Ø 0,51	Ø 0,62	Ø 0,74	Ø 0,88	Ø 1,1	Ø 1,6	Ø 2,3	Ø 2,6	Ø 3,0	Ø 3,3	Ø 4,5	Ø 6,2	Ø 7,1	Ø 7,9
	NW	Ø 0,34	Ø 0,51	Ø 0,62	Ø 0,74	Ø 0,88	Ø 1,1	Ø 1,6	Ø 2,3	Ø 2,6	Ø 3,0	Ø 3,3	Ø 4,5	Ø 6,2	Ø 7,1	Ø 7,9	Ø 8,8
TG7	W	Ø 0,37	Ø 0,57	Ø 0,82	Ø 1,0	Ø 1,2	Ø 1,4	Ø 1,7	Ø 2,6	Ø 3,5	Ø 4,0	Ø 4,5	Ø 5,0	Ø 7,4	Ø 10,0	Ø 11,3	Ø 13,0
	NW	Ø 0,57	Ø 0,82	Ø 1,0	Ø 1,2	Ø 1,4	Ø 1,7	Ø 2,6	Ø 3,5	Ø 4,0	Ø 4,5	Ø 5,0	Ø 7,4	Ø 10,0	Ø 11,3	Ø 13,0	Ø 14,0
TG8	W	Ø 0,57	Ø 0,88	Ø 1,3	Ø 1,6	Ø 1,8	Ø 2,3	Ø 2,7	Ø 4,0	Ø 5,7	Ø 6,5	Ø 7,4	Ø 8,0	Ø 11,3	Ø 16,0	Ø 18,0	Ø 20,0
	NW	Ø 0,88	Ø 1,3	Ø 1,6	Ø 1,8	Ø 2,3	Ø 2,7	Ø 4,0	Ø 5,7	Ø 6,5	Ø 7,4	Ø 8,0	Ø 11,3	Ø 16,0	Ø 18,0	Ø 20,0	Ø 22,0
TG9		Ø 0,85	Ø 1,4	Ø 2,1	Ø 2,6	Ø 3,0	Ø 3,5	Ø 4,2	Ø 6,4	Ø 9,0	Ø 10,0	Ø 11,5	Ø 13,0	Ø 18,0	Ø 24,0	Ø 28,0	Ø 33,0

NOTE 1 W: Tool-specific dimensions; NW: Non-tool-specific dimensions.
 NOTE 2 The differentiation of tool-specific and non-tool-specific dimension is not necessary for TG9.
 NOTE 3 Dimensions under 1 mm and above 1 000 mm are subject to mandatory agreement.
 NOTE 4 For validation of machine and process capability, see Annex E.

The prerequisites $P_2 = 1$ and $P_3 + P_4 \leq 3$ should apply for the line and area form tolerances (see Table 5, 6 and 7) for consideration of the moulded part properties.

The empirical tolerance values t from Table 10 in relation to the D_P nominal dimension shall be used for general tolerances for profile form areas.

Table 10 — General tolerances for profile forms

Dimensions in millimetres

D_P nominal dimension	≤ 30	> 30 to 100	> 100 to 250	> 250 to 400	> 400 to 1 000
Tolerance value t	0,5	1	2	4	6

7.3 Parting line/Tool offset

As a rule, visible parting lines are unavoidable in the production of plastic parts in the original mould process. The location of the parting lines shall be agreed between the manufacturer and buyer. A distinction must be made between a parting line and a parting offset here. (see Figure 3)

The essential influencing factors for the parting line are:

- moulded part design;
- viscosity of the plastics in the processing state;

The prerequisites $P_2 = 1$ and $P_3 + P_4 \leq 3$ should apply for the line and area form tolerances (see Table 5, 6 and 7) for consideration of the moulded part properties.

The empirical tolerance values t from Table 10 in relation to the D_p nominal dimension shall be used for general tolerances for profile form areas.

Table 10 — General tolerances for profile forms

Dimensions in millimetres

D_p nominal dimension	≤ 30	> 30 to 100	> 100 to 250	> 250 to 400	> 400 to 1 000
Tolerance value t	0,5	1	2	4	6

7.3 Parting line/Tool offset

As a rule, visible parting lines are unavoidable in the production of plastic parts in the original mould process. The location of the parting lines shall be agreed between the manufacturer and buyer. A distinction must be made between a parting line and a parting offset here. (see Figure 3)

The essential influencing factors for the parting line are:

- moulded part design;
- viscosity of the plastics in the processing state;
- processing parameters (essentially melt temperature, tool contour temperature, injection speed, tool inside pressure, tool retaining force and location of the changeover point);
- quality of the mould release in the tool (accuracy of the mechanical processing, hardness of the contour-giving component parts, service life of the tool).

In contrast, the size of the visible mould offset is affected by the precision during production of the tools and the centring precision of the processing machine.

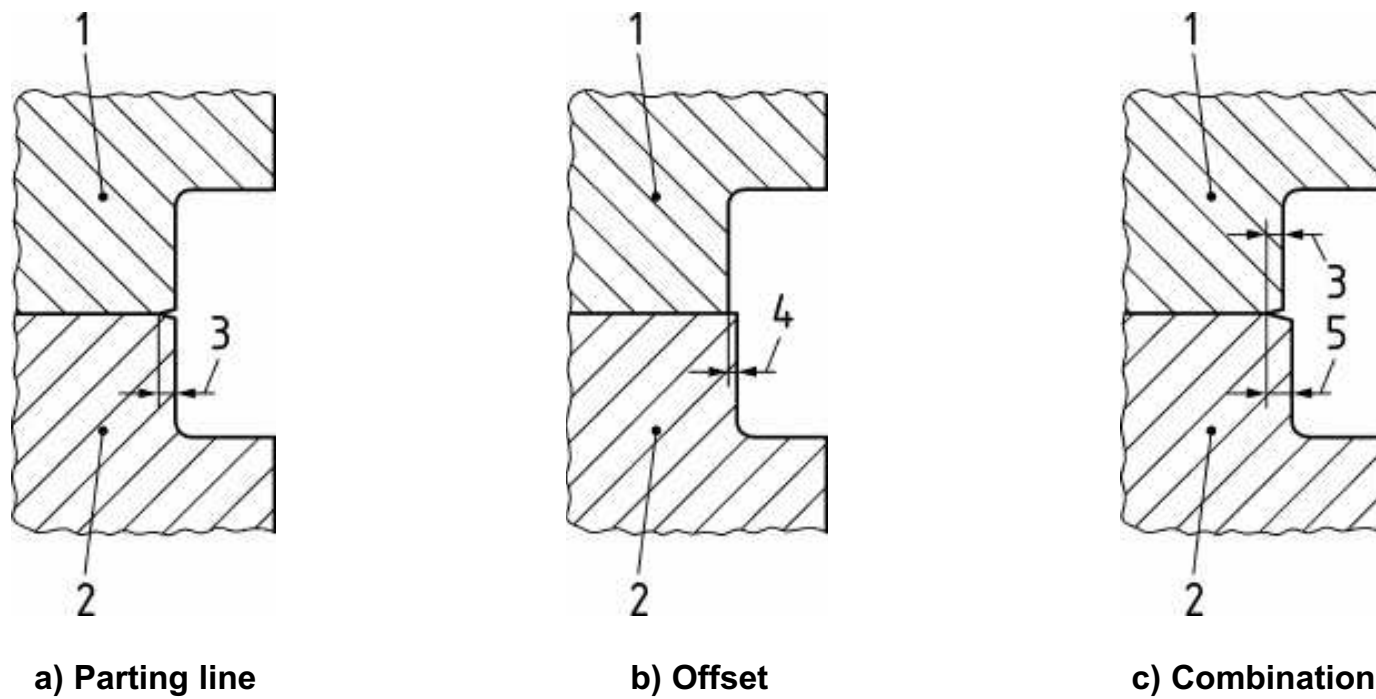

Key

- 1 Tool element 1
- 2 Tool element 2
- 3 Parting line
- 4 Offset
- 5 Parting line + offset

Figure 3 — Parting line/Tool offset

As a rule, combinations of both parting faults always occur (see Figure 3 c)).

A distinction is to be made into functional and subordinate areas here.

As a rule, the required mould parting conditions shall be defined in size and location for functional and subordinate areas. DIN EN ISO 10135 shall be used for the symbols.

7.4 Tolerancing of angular dimensions

Directly toleranced angles and edges are subject to mandatory agreement.

All angles and edges not directly toleranced are negligible for verification.

7.5 Tolerance analysis of dimension chains

The conventional tolerance chain calculation presupposes rigid bodies and is therefore primarily unsuitable for plastic parts. In case of tolerance analyses of dimension chains for non-stiff parts, chain members can be used as deformable compensation members for tolerance compensation for structures with less stiffness.

8 Acceptance conditions for moulded part production (ABF)

The test dimensions are regarded as acceptance values for normative acceptance conditions, if the moulded parts are stored at $23\text{ °C} \pm 2\text{ K}$ and $50\% \pm 10\%$ relative air humidity after production until acceptance as well as tested no earlier than 16 h and no later than 72 h after production.

If the above acceptance conditions are deviated from by the parts manufacturer, the acceptance parameters shall be agreed separately between the manufacturer and buyer and documented (e. g. in or on the labelling field with the note: Tolerancing ISO 8015 **AD** – “Agreement document”):

- dimensional location and dimensional deviations (if necessary, after testing);
- dimensional inspection method;
- minimum and maximum time period of the dimensional inspection after the parts production;
- storage and test conditions until parts acceptance (room air temperature, relative air humidity, if necessary a special storage regulation).

Such deviations from the usual acceptance conditions can be:

- follow-up operations at the parts manufacturer with material application (painting, coating) or material removal (cutting, grinding, polishing);
- parts aftertreatment by tempering (preliminary removal of the after-shrinkage, compensation of inner tensions, after-hardening) or follow-up operations with significant thermal parts load (painting, solder wire treatment etc.);
- parts aftertreatment by conditioning, e. g. by soaking (preliminary removal of the swelling, increasing toughness);
- low dimensional stability of structure and state of mould material for ABF. Examples are structural changes to the crystalline phase of semi-crystalline polymers (e. g. PB-1) and swelling as well as plasticisation as a result of water absorption of thin-walled moulded parts (below 2 mm) made from hydrophilic polymers (e. g. PA6, PA66, PA46; biopolymers).

Annex A (informative)

Dimensional reference levels for application and production of the moulded parts

A.1 Sizes and dimensional relations

Dimensional reference levels for application and production of the moulded parts for identification of the position (tolerance mean dimension C), the shift (dimensional shift ΔL) and the distribution (tolerance T) for the dimensional levels:

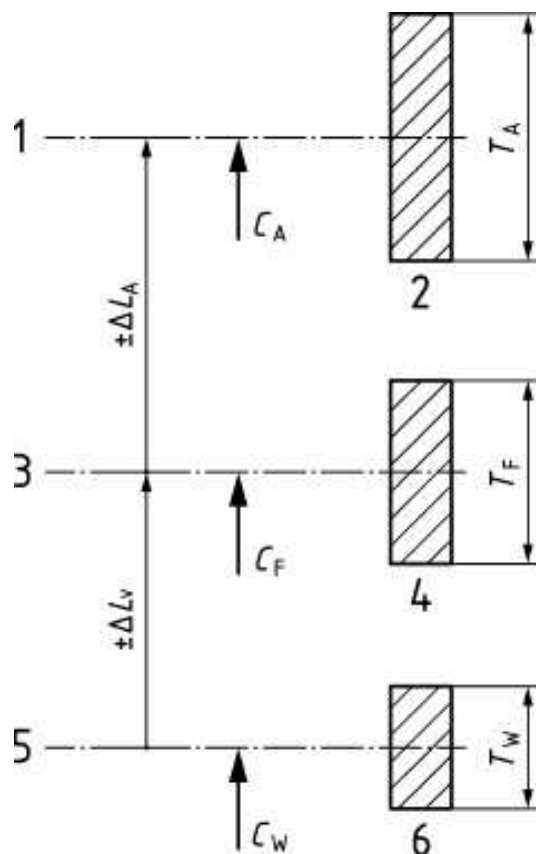

Key

- 1 Parts application (AWB)
- 2 Moulded part application tolerance (total tolerance)
- 3 Parts production (ABF)
- 4 Moulded part production tolerance
- 5 Tool production (ABW)
- 6 Tool contour production tolerance

Figure A.1 — Dimensional reference levels for application and production of the moulded parts

A.2 Application conditions (AWB)

Application conditions (AWB) are all utilisation and storage conditions of the parts during the application time period after production, insofar as they effect the dimensional stability and functional performance of the products.

Application-induced dimensional shifts ΔL_A result from the application conditions as situation-dependent overlapping of various individual influences with variations in time. Anisotropy effects can be of major significance in this respect.

The types and orientation of action are defined as follows:

- thermal expansion (+) or contraction (-): Dimensional change caused by temperature change, which ensues with little time delay to the temperature change of the parts and hence must always be considered.
- swelling (+) and/or post-moulding shrinkage (-): Dimensional change caused by molecular and micro-morphological structural processes as well as by diffusion and migration processes, which ensues with large time delay to the change of the relevant active factors and must hence be considered as a complex variable in relation to situation and time. After-shrinkage results from molecular short-range order effects (e. g. post-crystallisation, readjustment of molecular orientations), chemical reactions (e. g. post curing), dissipation of volatile components or drying out (e. g. water, condensation products, solvents and thinners, plasticisers), migration of liquid and solid components (e. g. plasticiser migration, chalking) as well as by relaxation (compensation) of elastic tensions. Swelling is caused by media absorption, in particular also water absorption.
- wear of internal dimensions (+) or external dimensions (-): Dimensional change caused by material abrasion, which is to be considered in relation to the type, size duration of the wear load (friction, cavitation, erosion).
- mechanical deformation as expansion (+) or compression (-): Part deformation caused by external forces and/or moments.

A.3 Processing-induced dimensional shift ΔL_V

Processing-induced dimension shift ΔL_V results from dimensional decrease (-) due to the moulding shrinkage and possibly from partial dimensional increase (+) as a result of dimensional corrections for dead compression areas (crushing areas), loose enclosures and jaws. The designation contour allowance is also normal for ΔL_V .

Annex B (informative)

Causes and influential factors on the moulding shrinkage of non-porous plastics

The causes and influential factors on the moulding shrinkage of non-porous plastics are shown in Table B.1.

Table B.1 — Causes and influential factors on the moulding shrinkage of non-porous plastics

Causes	Effect on the moulding shrinkage	
	reducing	increasing
Density increase as a result of thermal contraction due to cooling from demoulding temperature to room temperature and the compression due to the effects of pressure	<ul style="list-style-type: none"> • High effective pressure on moulding compound until demoulding and contour until demoulding (after-pressure) • Low demoulding temperature (long cooling time and/or low contour temperature) • Low coefficient of thermal expansion (hard-elastic polymers) 	<ul style="list-style-type: none"> • Low or premature withdrawn after-pressure until demoulding • High demoulding temperature (short cooling time and/or high contour temperature) • High coefficient of thermal expansion (soft-elastic or rubber-elastic polymers)
Density increase as a result of thermodynamically induced structural arrangement processes (crystallisation; gelation)	<ul style="list-style-type: none"> • Amorphous polymers • Low degree of crystallinity of semi-crystalline polymers due to rapid solidification (supercooling due to low contour temperature and/or thin-walled parts) • High degree of gelation of polymers containing plasticisers 	<ul style="list-style-type: none"> • Semi-crystalline polymers • High degree of crystallinity due to slow solidification (high contour temperature and/or thick-walled parts) as well as by improved nucleation (nucleation additives) • Low degree of gelation of polymers containing plasticisers
Density increase as a result of molecular structural and cross-linking processes (curing; vulcanisation; polyreaction)	<ul style="list-style-type: none"> • High degree of cross-linking and hence lower coefficient of thermal expansion (long curing or vulcanisation time and/or high mass temperature) • Moulding compounds essentially preformed or cross-linked materially (e. g. prepolymers) 	<ul style="list-style-type: none"> • Low degree of cross-linking and hence higher coefficient of thermal expansion (short curing or vulcanisation time and/or low mass temperature) • Non-cross-linked preproducts (oligomers) or monomers as moulding compounds
Stiffness or curing change due to additives (e. g. filling and strengthening agents; plasticisers)	<ul style="list-style-type: none"> • Additives with low coefficient of thermal expansion (e. g. inorganic filling and strengthening agents) • No or low plasticiser additives 	<ul style="list-style-type: none"> • Additives with high coefficient of thermal expansion (e. g. organic filling and strengthening agents) • Plasticiser additives

Annex C (informative)

Orientation aids for the assignment of plastic moulding compounds to tolerance groups

C.1 Assignment of tolerance series and tolerance groups

The assignment of the tolerance groups can be seen in Table C.1.

Table C.1 — Tolerance series and tolerance groups

Tolerance series	Tolerance groups					
	A	B	C	D	E	F
Series 1: Normal production	TG4	TG5	TG6	TG7	TG8	TG9
Series 2: Accurate production	TG3	TG4	TG5	TG6	TG7	TG8
Series 3: Precision production	TG2	TG3	TG4	TG5	TG6	TG7
Series 4: Precision special production	TG1	TG2	TG3	TG4	TG5	TG6

C.2 Injection moulding and injection compression moulding of amorphous thermoplastics with glass temperatures above 60 °C

PS, SB, SAN, ABS, CA, CAB, CP, CAP, PVC-U, PVC-HI, ASA, PETam, PMMA, PMMA-HI, (ASA+PMMA), MABS, MBS, (PPE+SB), PC, (PC+ABS), (PC+ASA), PEI, PA6-3-T, COC, PESU, PSU, PPSU and others.

- Highest VS under 0,5 %. Shrinkage anisotropy is possibly considered. → **A**
- Without filling and strengthening agents or no shrinkage anisotropy due to filling and strengthening agents, so that the calculated value of the VS
 - at approx. ± 10 % is complied with → **A**
 - or not complied with. → **B**
- Distinct shrinkage anisotropy due to filling and strengthening agents (e. g. fibre reinforcement), which in the contour dimensioning
 - is sufficiently considered → **B**
 - or not considered. → **C**

C.3 Injection moulding of semi-crystalline thermoplastics

PE, PP, PET, PBT, (PBT+PC), (PBT+ASA), PPS, PVDF, PCTFE, PFEP, ETFE, ECTFE, PFA, POM, PA6, PA6-HI, PA66, PA66-HI, PA6/66, PA6I, PA6/6T, (PA66+PPE), PA610, PA612, PA46, PA11, PA12, PAMD6, PEEK, PEK and others.

- Highest VS under 0,5 %. Shrinkage anisotropy is possibly considered. → **A**
- Moulding compound without filling and strengthening agents with
 - Modulus of elasticity over 1 200 N/mm²
 - Calculated value of the VS under 1 % → **B**
 - Calculated value of the VS 1 % to 2 % → **C**
 - Calculated value of the VS over 2 % → **D**
 - Modulus of elasticity under 1 200 N/mm²
 - Calculated value of the VS under 1 % → **C**
 - Calculated value of the VS 1 % to 2 % → **D**
 - Calculated value of the VS over 2 % → **E**
- Moulding compound with filling and strengthening agents
 - without noteworthy shrinkage anisotropy or with its consideration for contour dimensioning → **B**
 - without consideration of the shrinkage anisotropy for contour dimensioning. → **C**

C.4 Injection moulding of soft-elastic thermoplastics and thermoplastic elastomers (TPE) without filling and strengthening agents

PVC-P, PA12-P, EVAC, TPS-SEBS, TPS-SBS, TPO-(EPDM+PP), TPO-(EVAC+PVDC), TPV-(EPDM-X+PP), TPC, (TPC+PBT), TPU, TPA and others.

- Calculated value of the VS under 1,5 % see **I**
- Calculated value of the VS over 1,5 % and no noteworthy shrinkage anisotropy see **I**
- Calculated value of the VS over 1,5 % and distinct shrinkage anisotropy, which due to the moulded part and tool design as well as the moulding process
 - can be adequately compensated see **I**
 - cannot be compensated. see **II**

The assignment can be seen in table C.2.

Tabelle C.2 — Curing classification

Curing classification	I	II
Shore D > 35	C	D
Shore A 50 to 90	D	E
Shore A < 50	E	F

C.5 Injection moulding of liquid crystalline (thermotropic) polymers (LCP)

NOTE A distinct shrinkage anisotropy is often unavoidable at a relatively low shrinkage level due to the flow orientation of rigid molecules. Filling and strengthening agents tend to reduce this anisotropy.

- Highest VS under 0,5 % → **A**
- Effect of the shrinkage anisotropy on the production accuracy due to the moulded part and tool design as well as the moulding process
 - can be adequately compensated → **A**
 - cannot be compensated. → **B**

C.6 Compression moulding and impact extrusion of glass mat reinforced thermoplastics (GMT)

Moulding compounds: Thermoplastic impregnated glass mat prepregs with glass contents over 15 %.

- Highest VS under 0,5 % → **B**
- Effect of the shrinkage anisotropy on the production accuracy due to the moulded part and tool design as well as the moulding process
 - can be adequately compensated → **B**
 - cannot be compensated. → **C**

C.7 Injection moulding, injection compression moulding, transfer moulding and compression moulding of thermoset moulding compounds

PF, UF, MF, MPF, UP, EP, PDAP, PUR-X, SI-X and others.

The assignment of the thermoset moulding compounds can be seen in table C.3.

Table C.3 — Assignment of thermoset moulding compounds

	Injection moulding Injection compression moulding Transfer moulding	Compression moulding
Highest VS under 0,5 %	A	B
Anticipated shrinkage distribution in relation to the calculated value of the VS with consideration of the shrinkage anisotropy:		
approx. $\pm 10\%$	A	B
approx. $\pm 20\%$	B	C
$\geq \pm 30\%$	C	D

Annex D
(informative)

Evaluation of the production expense

The evaluation criteria listed in Table D.1 for the production expense for classification of the tolerance series are to be understood as an orientation aid. According to the current experience of the user, they can be supplemented and weighted differently.

Table D.1 — Differentiation options or required expense

Criterion	Normal production	Accurate production	Precision production	Precision special production
Injection moulding machine / machinery	Standard injection moulding machines without monitoring of the process parameters	Standard injection moulding machine with monitoring of the process parameters	Production on controlled injection moulding machines with extended monitoring options for additional pressure sensors and temperature sensors	Production on specified machines with stationary machine assignment
			Increased special monitoring expense of the machines (calibration)	
			Machines with especially stiff structure	
	Production without stationary machine assignment possible			
Infrastructure / Periphery	Injection parts can be produced off-tool.		Tempering media – flow temperature controlled (± 1 K)	
			Controlled tempering ΔT flow – return max. (1,5 to 2,5 K)	
			Forced circulation without bridging	
			Sufficiently accurate monitoring of the mass temperature (hot runner)	
			Handling devices for insertion of insertion parts for the removal of the injection parts	
			Dry-air dryer for hydrophilic moulding compounds	
			Defined cooling sections for the injection parts until removal	
Environmental conditions	Production in normal workshop environment conditions		Production with restricted room climate conditions or in air-conditioned rooms	
			Injection moulding machines possibly specially insulated (e. g. plasticisation)	
Tool	Tools with change inserts permissible	Tools with few change inserts permissible	Tools without change inserts. No family tools (group tools)	
			The production method for the tool contour for the directly tolerated geometry elements must enable the required accuracy. (For example, the accuracy of a ground contour cannot be attained with erosion.)	
			The number of cavities and the complexity of the geometry affect the tolerances that can be complied with over all cavities.	
			Balanced thermal conditions in the tool	
			Demoulding with low mechanical stress of the injection parts	
			Sufficiently precise and stiff guidance of the moving tool components	
	Production accuracy normal	Production accuracy average	Production accuracy very high	

Table D.1 — Differentiation options or required expense

Criterion	Normal production	Accurate production	Precision production	Precision special production
Injection moulding machine / machinery	Standard injection moulding machines without monitoring of the process parameters	Standard injection moulding machine with monitoring of the process parameters	Production on controlled injection moulding machines with extended monitoring options for additional pressure sensors and temperature sensors	
			Increased special monitoring expense of the machines (calibration)	
			Machines with especially stiff structure	
	Production without stationary machine assignment possible		Production on specified machines with stationary machine assignment	
Infrastructure / Periphery	Injection parts can be produced off-tool.		Tempering media – flow temperature controlled (± 1 K)	
			Controlled tempering ΔT flow – return max. (1,5 to 2,5 K)	
			Forced circulation without bridging	
			Sufficiently accurate monitoring of the mass temperature (hot runner)	
			Handling devices for insertion of insertion parts for the removal of the injection parts	
			Dry-air dryer for hydrophilic moulding compounds	
			Defined cooling sections for the injection parts until removal	
Environmental conditions	Production in normal workshop environment conditions		Production with restricted room climate conditions or in air-conditioned rooms	Injection moulding machines possibly specially insulated (e. g. plasticisation)
Tool	Tools with change inserts permissible	Tools with few change inserts permissible	Tools without change inserts. No family tools (group tools)	
			The production method for the tool contour for the directly toleranced geometry elements must enable the required accuracy. (For example, the accuracy of a ground contour cannot be attained with erosion.)	
			The number of cavities and the complexity of the geometry affect the tolerances that can be complied with over all cavities.	
			Balanced thermal conditions in the tool	
			Demoulding with low mechanical stress of the injection parts	
			Sufficiently precise and stiff guidance of the moving tool components	
			Production accuracy normal	Production accuracy average

Table D.1 (continued)

Criterion	Normal production	Accurate production	Precision production	Precision special production
Moulded part design	Plastic compatible design		Plastic compatible design with filling simulation and deformation calculation	
			Moulded part design must enable homogenous tempering	
			Only few closely toleranced dimensions	
Moulding compound	Recyclate can be used	Recyclate definitely useable	Check wear of the tool contours in case of abrasive additives	
			Moulding compounds only type ware	Moulding compounds only type ware with restricted supply tolerances (specified moulding compound)
Insertion parts	Purchased parts with standard tolerances		Purchased parts with reduced tolerances	
			If necessary, 100 % check of especially closely toleranced and important dimensions / characteristics	
			Handling devices for insertion of insertion parts	
Personnel	Trained personnel	Specifically trained technical personnel	Trained and qualified personnel with more detailed knowledge or process optimisation	
Quality monitoring	Startup and concluding inspection	Startup and concluding inspection with specified interim tests	Startup and concluding inspection with closely meshed quality tests	Startup and concluding inspection with process-monitored closely-meshed quality tests of the specially toleranced dimensions through to equipment for the 100% inspection of these dimensions
			3D measuring system	3D measuring system of higher accuracy class
Process documentation	Present		Present with batch management	
Parts packaging	After agreement		Special packaging adapted to the part	Special packaging adapted to the part, if necessary individual packaging in trays/ layers / palletisation
				Depending on material, specially defined transport and storage conditions

Table D.1 (continued)

Criterion	Normal production	Accurate production	Precision production	Precision special production
Moulded part design	Plastic compatible design		Plastic compatible design with filling simulation and deformation calculation	
			Moulded part design must enable homogenous tempering	
			Only few closely toleranced dimensions	
Moulding compound	Recyclate can be used	Recyclate definitely useable	Check wear of the tool contours in case of abrasive additives	
			Moulding compounds only type ware	Moulding compounds only type ware with restricted supply tolerances (specified moulding compound)
Insertion parts	Purchased parts with standard tolerances		Purchased parts with reduced tolerances	
			If necessary, 100 % check of especially closely toleranced and important dimensions / characteristics	
			Handling devices for insertion of insertion parts	
Personnel	Trained personnel	Specifically trained technical personnel	Trained and qualified personnel with more detailed knowledge or process optimisation	
Quality monitoring	Startup and concluding inspection	Startup and concluding inspection with specified interim tests	Startup and concluding inspection with closely meshed quality tests	Startup and concluding inspection with process-monitored closely-meshed quality tests of the specially toleranced dimensions through to equipment for the 100% inspection of these dimensions
			3D measuring system	3D measuring system of higher accuracy class
Process documentation	Present		Present with batch management	
Parts packaging	After agreement		Special packaging adapted to the part	Special packaging adapted to the part, if necessary individual packaging in trays / layers / palletisation
				Depending on material, specially defined transport and storage conditions

Annex E (informative)

Validation of machine or process capability

The production tolerances indicated in the present standard are to be regarded as minimum possible tolerances. No additional scopes for the validation of machine or process capability are calculated in these tolerances. Very many different factors have an effect on the dimensioning, with the result that a process control in the actual sense of control card systems is not normally possible. Rather, control cards are used for monitoring and documentation of the injection process, for example. If machine or process capability validations are required, a broadening of the tolerances is necessary so that sufficient scope from the tolerance limits to the mean value is established in which the process can move.

In addition to the machine and process capability validations, validation of the measuring instrumentation capability is often required. The validation of the measuring instrumentation capacity according to the ANOVA model cannot be applied to the injection moulding process, as the entire process width cannot be simulated in the injection process and hence the process distribution in relation to the measuring instrumentation distribution is too low.

Annex E
(informative)

Validation of machine or process capability

The production tolerances indicated in the present standard are to be regarded as minimum possible tolerances. No additional scopes for the validation of machine or process capability are calculated in these tolerances. Very many different factors have an effect on the dimensioning, with the result that a process control in the actual sense of control card systems is not normally possible. Rather, control cards are used for monitoring and documentation of the injection process, for example. If machine or process capability validations are required, a broadening of the tolerances is necessary so that sufficient scope from the tolerance limits to the mean value is established in which the process can move.

In addition to the machine and process capability validations, validation of the measuring instrumentation capability is often required. The validation of the measuring instrumentation capacity according to the ANOVA model cannot be applied to the injection moulding process, as the entire process width cannot be simulated in the injection process and hence the process distribution in relation to the measuring instrumentation distribution is too low.

Annex F (informative)

Main causes for dimension, form and location deviations in moulded part production

The main causes for corresponding dimensional deviations are:

- moulding compound and moulding-induced distribution of the moulding shrinkage;
- uncertainties when determining calculated values of the moulding shrinkage for the tool contour calculation, in particular in case of large shrinkage values and for shrinkage anisotropy;
- different elastic recovery capacity of the parts after demoulding, depending on moulding compound stiffness or hardness;
- tool contour wear;
- production-induced dimensional distribution of the tool contours including deformation due to hardening and surface coating;
- deformations of tool parts as a result of pressure loads.

Form, location and angle deviations created due to deformation of the moulded parts as a result of shrinkage anisotropy and possibly due to the compensation of elastic tensions after demoulding in interaction with the moulded part design.

Annex G
(informative)

Example for determining the D_p dimension for application of Table 9

Dimensions in millimetres

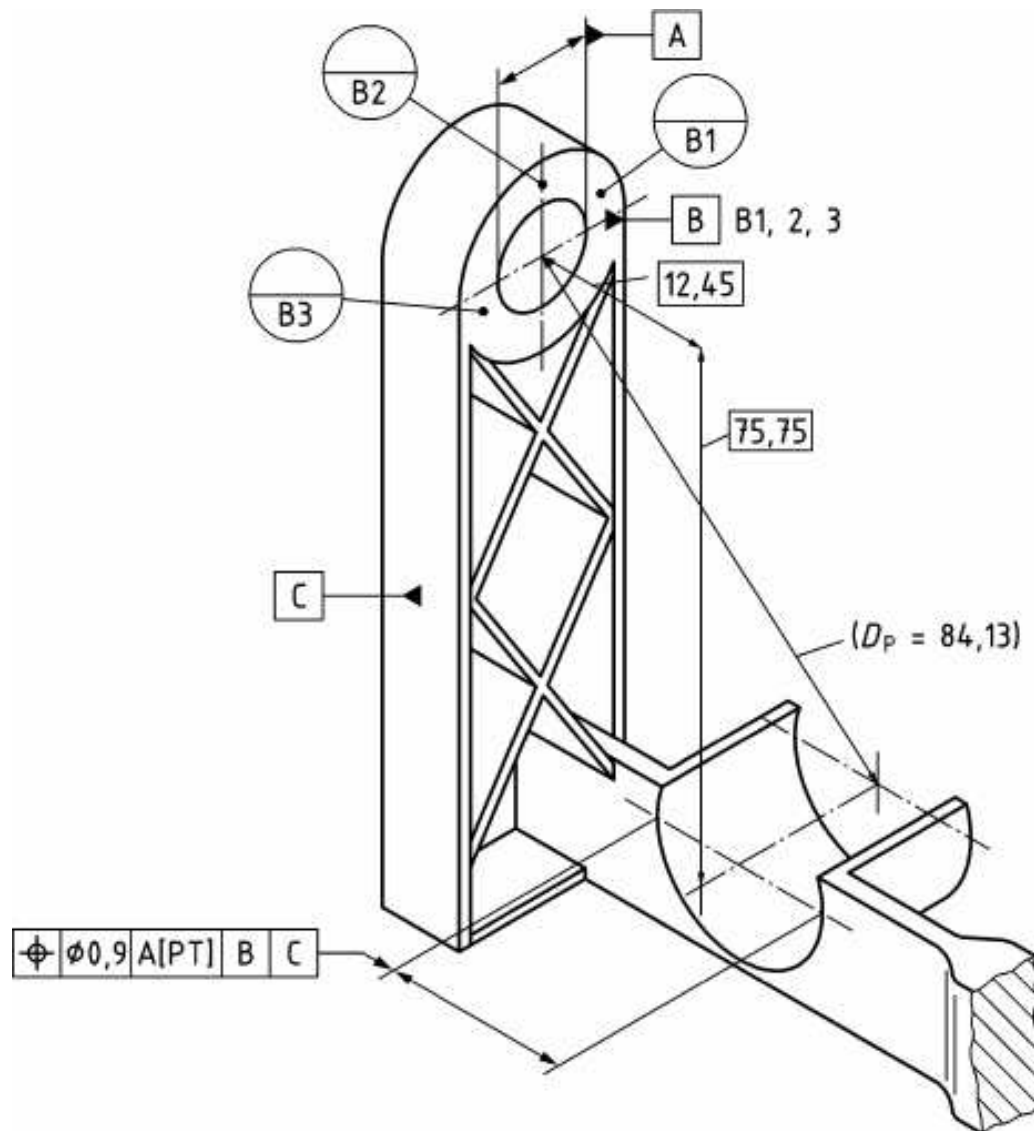

Bild G.1 — Example diagram for determination of the D_p dimension

The D_p dimension is determined according to 7.2 as the furthest distance in the room between the element to be tolerated and the origin of the reference system used for this position tolerance.

This distance is $D_p = 84,13$ mm here. The technologically tenable position tolerance is $\varnothing 0,9$ mm for TG 4 according to DIN 16742, Table 9 (not tool specific).

NOTE If a dimensional tolerance is selected as a length dimension for the dimensioning of the semi shells instead of the geometrical tolerancing, Table 2 is consulted and the tolerance for the length dimension 12,45 mm determined there used for determination of the tolerance for the dimension 12,45 mm with $D_p = 84,13$ mm. When indicating DIN 16742 – TG4 the dimension 12,45 mm receives the tolerance $\pm 0,32$ mm in the above example.